



Manufacturer and Supplier of
Restaurant Equipment
 and **Display Cases**
 for the Food Service Industry



MODEL: OPC-8

PRODUCT FEATURES

- Four shelves
- 5 levels of display
- Light under every shelf
- 16" stainless steel shelves
- Remote controlled system
- Black formica sides
- Illuminated Top
- Night cover included

Endless Open Produce Case

Custom colors available to match your decor

Casters	NA
Warranty	1 yr Parts
Front	Open
Front Motor Cover	NA
Interior Walls	White Aluminum
Outside Back	Galvanized

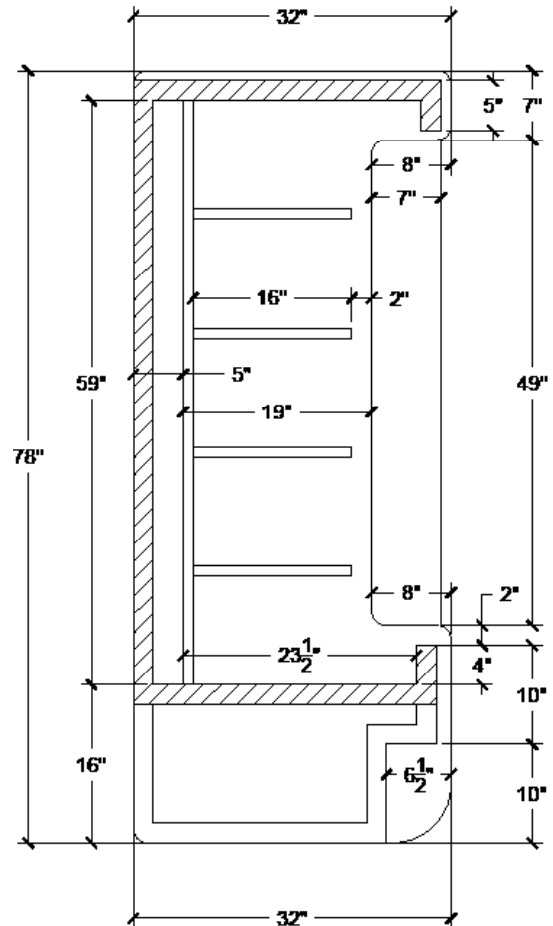

Product Specifications

Dimensions	Doors	Shelves	Cooling Cycle	Refrigerant	HP*	Power	Ampr.	BTU	Freon (oz)
96" X 32" X 78"	0	8	33-41	NA	2	115/60/1	12.5	5500	NA

Additional Models

* Recommended Condensing Unit

Model #	Doors	Shelves	Cooling Cycle	Refrigerant	HP*	Power	Ampr.	BTU	Freon (oz)
OPC-4	0	4	33-41	NA	1	115/60/1	8	1700	NA
OPC-6	0	4	33-41	NA	1 1/2	115/60/1	12.5	1200	NA
OPC-10	0	8	33-41	NA	3	115/60/1	12.5	4300	NA
OPC-12	0	8	33-41	NA	3	115/60/1	14.5	6000	NA

* Model number designates number of doors. Due to product improvement, we reserve the right to change specifications without notice.