



Manufacturer and Supplier of
Restaurant Equipment
 and **Display Cases**
 for the Food Service Industry



MODEL: SC-48-BMD

PRODUCT FEATURES

Mega top sandwich prep

- 2 pull out Stainless Steel doors
- 30% More interior space
- 2" recessed pans (keeps food in colder storage area)
- side mounted evaporator system
- Self-contained
- Flts (3) hotel size pans
- Interior lighting
- Holds 33°-41°F temperatures
- Compressor can be serviced easily
- Environmentally friendly 134A refrigerant
- 8" plastic cutting board

- | | |
|-------------------|-------------------------|
| Casters | 5" Casters Optional |
| Warranty | 1 yr Parts & Compressor |
| Front Door | Stainless Steel |
| Front Motor Cover | Anodized Aluminum |
| Interior Walls | Stainless Steel |
| Outside Back | Galvanized |

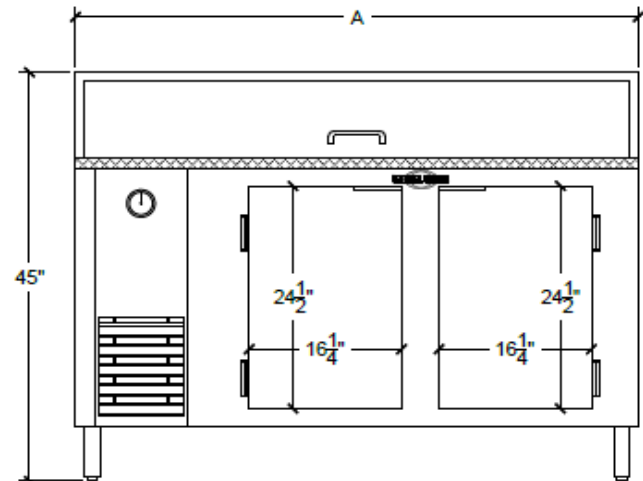
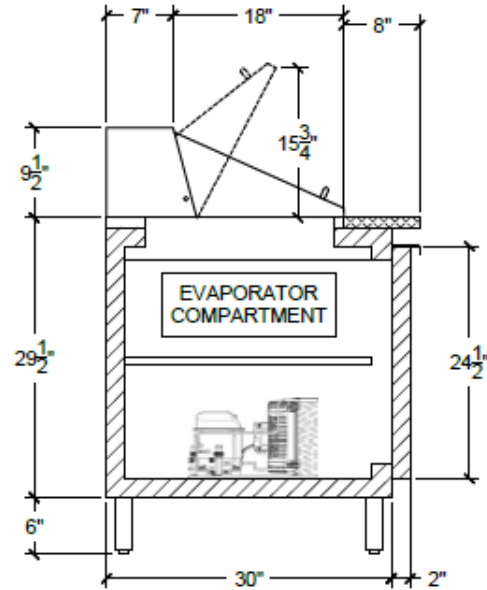

Product Specifications

Dimensions	Doors	Shelves	1/6 Pans	Refrigerant	HP	Power	Ampr.	BTU	Freon (oz)
48" x 32" x 45"	2	2	18	134a	1/3	115/60/1	7.5	900	11.5

Additional Models

Model	Doors	Shelves	1/6 Pans	Refrigerant	HP	Power	Ampr.	BTU	Freon (oz)
SC-60-BMD	2	2	20	134a	1/3	115/60/1	8.5	900	11.5
SC-72-BMD	3	9	30	134a	1/3	115/60/1	9	1200	11.5

* Model number designates number of doors. Due to product improvement, we reserve the right to change specifications without notice.